

By: Speed Post/ Registered A.D.

GOVERNMENT OF INDIA
OFFICE OF THE GENERAL MANGER
GOVERNMENT OPIUM & ALKALOID WORKS
NEEMUCH 458441 MADHYA PRADESH

TEL : 220199, 220614
F.No: I[20] 023 / P./ E / 2017-

FAX : 07423-220647
Dated the : 02 / 01 / 2018

To,

M/s. _____

D/Sir,

Subject : Supply of Quotation for SHELL & TUBE CONDENSER.

Please forward your Quotation in double sealed cover for supply of following items addressed to the General Manager, Govt. Opium & Alkaloid works, Neemuch 458441 (M.P.); On or before 15.00 hrs. of 09 / 02 / 2018. Your offer would be governed by terms & conditions as mentioned below: -

Sl.	Description of Stores	Quantity
1	SHELL & TUBE CONDENSER SPECS., MOC as per drawing attached	02 Nos.

02. Our file No. & date and due date should be clearly written on your quotation.
03. The quotation should be sent in double sealed cover duly subscribed on both the covers in bold letters 'Tender for 'SHELL & TUBE CONDENSER'' to be opened on: 9 / 02 / 2018.
04. The quotation should be sent through Courier / Post or may be dropped personally by the tender(s) or their representatives in the Tender Box available in the office of the General Manager of this works.
05. The quotation should bear no correction or alteration and it should be duly signed by a competent person. The name and designation of the signatory should also be given.
06. Net rates after discount should be quoted; the rates should be given in figures and words. The rates should be free from cuttings, alteration or over writing. Rates should be quoted only for the specified Make & units. Offer / Quotation(s) received after specified date and time shall be rejected out rightly.
07. Rates should be valid for a minimum period of 60 days and till completion of supply.
08. All the rates should be quoted F.O.R. Neemuch [M.P.] Neemuch is located Mhow-Nasiharabad Highway, 56 Kms. from Chittrogarh, 133 Kms. from Ratlam and 135 Kms. from Udaipur.
09. The claim of any damage, breakage and loss in transit would be made good by company to this office & the supplier will settle claims directly with the insurance company at his own responsibility.

10. The General Manager reserves the right to not accept the lowest or any quotation and split up offer & place order(s) with one or more tendered without assigning any reason whatsoever.
11. Earnest Money Deposit of 02% of the total value should be deposited in the form of cash or by way of account payee Bank Draft in favour of 'DRAWING & DISBURSING OFFICER' GOVT. OPIUM & ALKALOID WORKS, NEEMUCH 458441 MP towards Earnest Money Deposit.
12. No interest on Earnest Money / Security deposit shall be paid. Earnest Money deposit of unsuccessful tenderers will be refunded with in a reasonable period without any interest.
13. The % of GST will clearly be mentioned in the quotation as well as supply invoice (if supply order placed).
14. The claim of any damage, breakage and loss in transit would be made good by the supplier to the undertaking and the supplier will settle the claim directly with the Insurance Company at his own.
15. The General Manager reserves the right not to accept the lowest or any quotation and split up the quotation and place order with one or more tenderers without assigning any reason whatsoever.
16. You must be able to supply the articles immediately / within **07** days as per the delivery schedule to be given in our purchase order.
17. The quantity shown in our enquiry is approximate and can be increased or reduced by us. If rates for small / large lots are different, these should be quoted separately.
18. Packing and forwarding charges if any and taxes and insurance charges if any should be clearly mentioned otherwise the rates will be treated as **INCLUSIVE OF** all these. Form C/D will be issued on demand.
19. Full technical literature, catalogue, pamphlet, test reports and other information etc. should be forwarded with quotation to ascertain the suitability of stores offer by you and your capacity to supply it.
20. If you are on rate contract with the D.G.S.&D or any other Department of Govt. of India for these items only such rates should be quoted and mention to this effect be made in the quotation.
21. Delivery is the essence of the contract if delivery is not made as per terms of the purchase order; the Undertaking reserves the right to forfeit the Earnest Money Deposit/ Security Deposit.
22. RISK PURCHASE: In case the stores is not supplied within the stipulated period as per purchase order or of sub-standard quality of stores supplied by you, the Undertaking reserves the right to purchase stores from any other available source. If any extra expenditure incurred due to such purchase, the extra expenditure shall be borne by the supplier. In this regard, the notice given by the Undertaking will be Final and binding without any dispute.
23. The quantity and quality of the stores shall be verified at our Works, in case of defective/not as per the specifications, the Undertaking reserves the right to reject the stores at the cost of the supplier.
24. Dispute if any, will be subject to Neemuch (M.P) jurisdiction.

Yours faithfully,



MANAGER
GOVT. OPIUM & ALKALOID WORKS
NEEMUCH-458 441 (M.P.)

General Terms and ConditionsNo. _____
Date - 14-11-2018

- (1) Tender/quotation will be received in two separate sealed cover. Technical bid consisting all technical details, and along with the commercial terms and conditions, and valid NSIC/MSME/SSI registration, past experience certificate etc.

The financial bid indicating price for the items/stores mentioned in the enquiry. The technical and financial bids should be sealed by the bidder in separate cover duly super scribed the above File No., and both these sealed cover are to be put in a bigger cover which should also be sealed and duly super scribed with File No., and it must be delivered to this works either by registered / speed post, courier or by person. The tender box is kept at main gate of this office, near CISF control room.

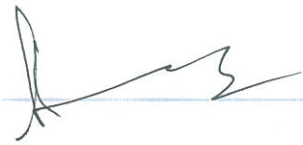
- (2) The tenderer must have experience and carried out similar type of fabrication work related to plants like chemical/pharma/extraction etc.
- (3) The bidding firm should be at least SSI/MSME registered.
- (4) The financial bid only those bidders shall be opened whose offers (i.e. technical bid) are found to be technically acceptable.



(Y. CHAKRAPANI)
WORKS ENGG.

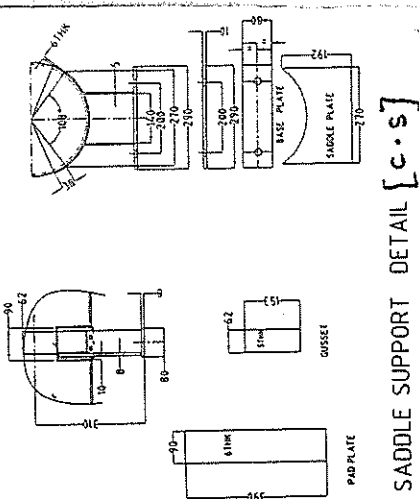

SADDLE SUPPORT DETAIL [C.S.]

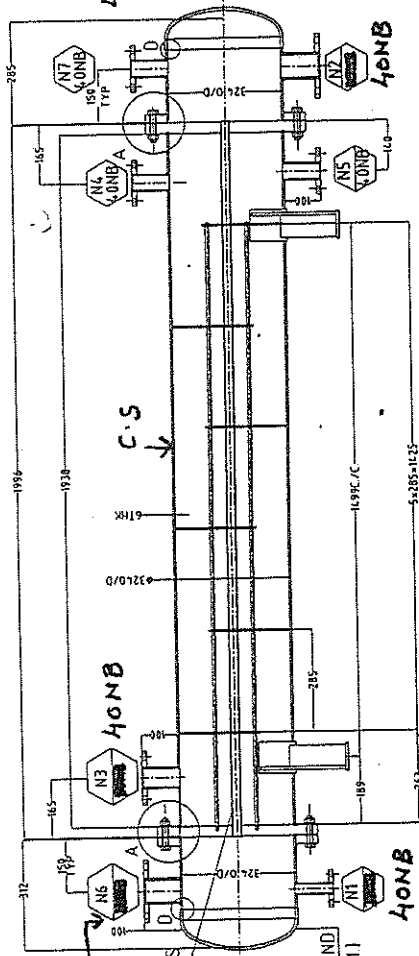
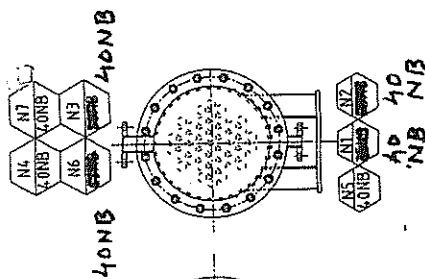

40NB

Tube dia 25.4 o/d

NOS OF TUBES - 44 NOS

TORISPHERICAL DISH END

7THK (MIN.), 8THK (NOM) 1

KR=50. ICR=266 (TYP.)

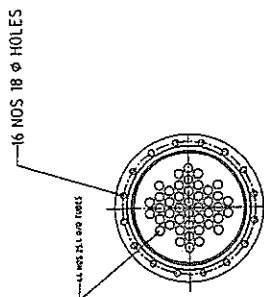

GASKET
QTY - 2 NOS
HOC - CAF
MOC - HANS

C.S.

Channel Support

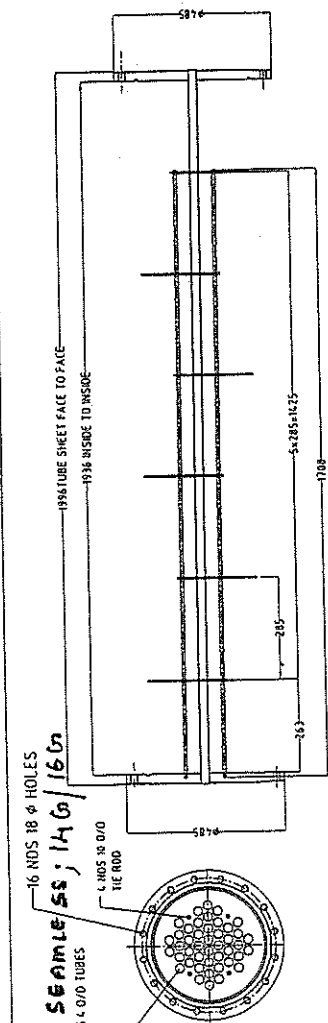

S.S 316 SEAMLESS; 146 / 160

4 NOS 30 Ø/O

1 IE ROD

TUBE BUNDLE DETAIL

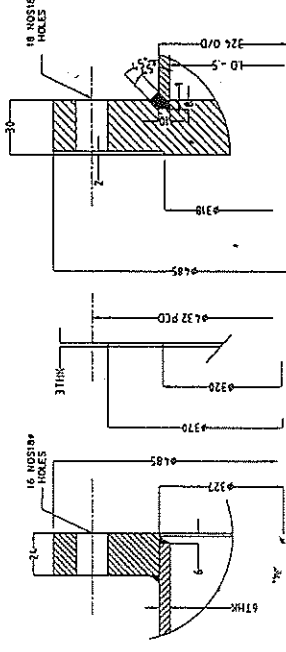

DETAIL AT A

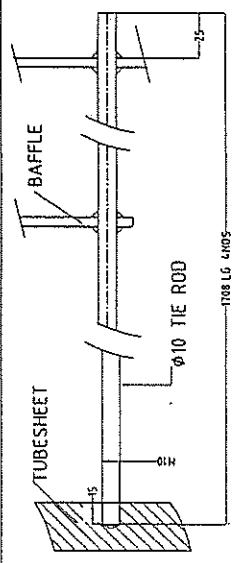

TIE ROD WELD DETAIL

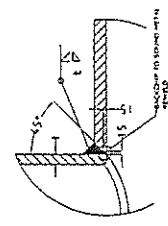

SHELL TO NOZZLE WELD JOINTS

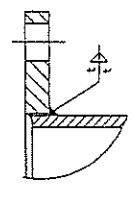

NOZZLE TO FLANGE WELD JOINTS

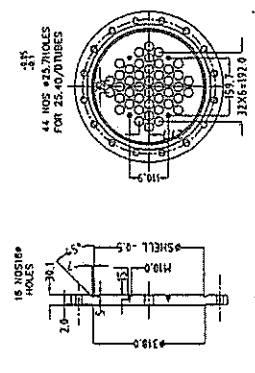

L H S TUBESHEET
QTY -1NO
MOC - C.S

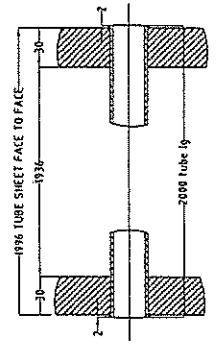

TUBE TO TUBE SHEET WELD DETAIL

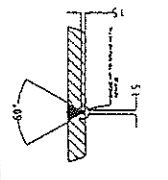

SHELL CIR.&LONG SEAM WELD JOINTS

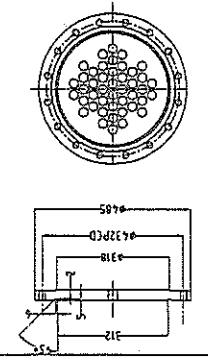

R H S TUBESHEET
QTY -1NO
MOC - C.S

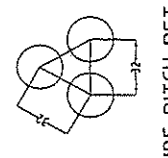

TUBE PITCH DETAIL

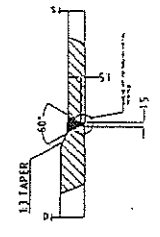

DETAIL AT O

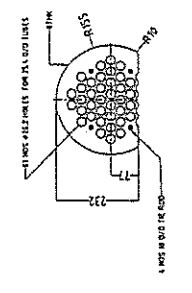

BAFFLE -6 NOS
MOC - C.S

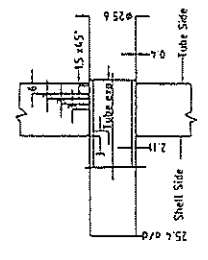

TUBE TO TUBE SHEET EXPANDING DETAIL

DESIGN DATA

A	DESIGN PRESSURE	(Kg/cm ² g)	6 Kg/Cm ²
B	DESIGN TEMPERATURE	(C)	120
C	OPERATING PRESSURE	(Kg/cm ² g)	-
D	OPERATING TEMPERATURE	(C)	-
E	PNEUMATIC PRESSURE	(Kg/cm ² g)	-
G	CORROSION ALLOWANCE	(M.M)	NIL
H	HEAT TRANSFER AREA	(M ²)	4.0
I	JOINT EFFICIENCY		0.7
J	RADIOGRAPHY (X RAY)		-
K	X RAY/UT		N.A.
L	STRESS RELIEVING/SOLUTION ANEALING		N.A.
M	FLUID HANDLED		TOLUENE VAPOURS
N	INSPECTION BY		
O	EMPTY WEIGHT	KGS.	~438

GENERAL NOTES

- 1 ALL DIMENSIONS ARE IN MM UNLESS OTHERWISE NOTED.
- 2 VESSEL CONSTRUCTION & INSPECTION CODE:- ASME SECT. VIII DIV.- & TEMA
- 3 ALL WELDING TO BE CONTINUOUS UNLESS OTHERWISE SPECIFIED.
- 4 ALL WELDING TO BE THOROUGHLY WIRE BRUSHED AND CLEANED TO REMOVE RUST, SCALE, SLAG ETC.
- 5 ALL SHARP CORNERS TO BE ROUNDED OFF.
- 6 EQUIPMENT SHALL BE THOROUGHLY DRIED AND CLEANED INTERNALLY AND EXTERNALLY PRIOR TO SHIPMENT.

N7	40	300	AIR VENT	1	150#	
N6	40	300	WATER OUTLET	1	150#	
N5	40	300	CONDENSATE	1	150#	
N4	40	300	AIR VENT	1	150#	
N3	40	300	VAPOUR	1	150#	
N2	40	300	WATER INLET	1	150#	
N1	40	300	DRAIN	1	150#	
NOZZ. MARK	size	300	SERVICE	QTY.	FLG RAT #	REMARKS

C/S NOZZLE SCHEDULE

NOTE 1 ① SCHEDULE PIPE SHALL BE USED FOR ALL NOZZLES

② ALL NOZZLES SHALL BE PROVIDED WITH EXTRA COUNTER FLANGES, WITH NUT & BOLTS.